

Sonderanschlüsse auf Anfrage
Special connections on request
D'autres raccords sur demande

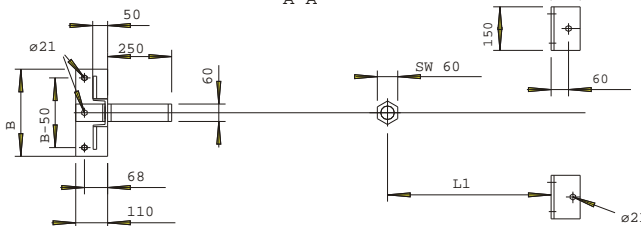

Anschlussvarianten DIN 2501

Connections DIN 2501

Raccords DIN 2501

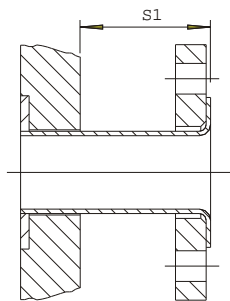

Losser Flansch F, Bördel G
Lapped flange F, flange G
Bride type F, type G
DIN 2641 (PN6)
DIN 2642 (PN10)

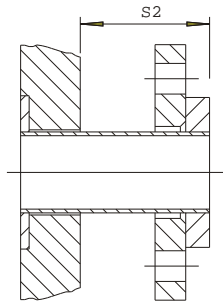

Losser Flansch F, glatter Bund B
Lapped flange F, plain collar B
Bride type F, type B
DIN 2656 (PN25)

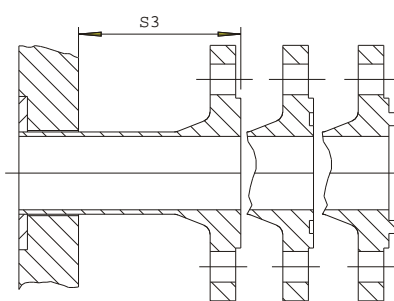

Vorschweißflansch C (N,F)
Welding neck flange C (N,F)
Bride a souder a type C (N,F)
DIN 2631 (PN6)
DIN 2632 (PN10)
DIN 2633 (PN16)
DIN 2634 (PN25)

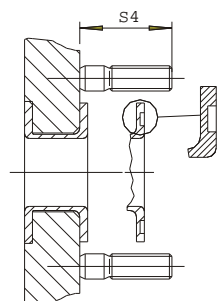

Stehbolzen
Durchgang mit
Auskleidung
Stud bolts with
lining
Goujon
Passage avec chemise

L	500	750	1000	1250	1500	1750	2000	2250	2500	2750	3000	3250	3500	3750	4000					
L1	1400																			
H						180					210					230				
B											300									
DN	150																			

PN	S	S1	S2	S3	S4
6		125...130	150...160	150...160	60
10		110...120	150...160	150...185	60
16		X	160...180	155...185	70
25		X	170...190	170...185	80



Angebotsskizze (Techn.Änderungen vorbehalten)
Sketch of offer (Subject to Technical Modifications)
Plan (Sous reserve de confirmation apres commande)

850K.IL-A-Z	1	13.03.03				
Dok.Nr./doc.no.	Rev./rev.	Dat./date	gez./draw	geg./check	freig./approv.	

Plattenwärmeübertrager
Plate heat exchanger
Echangeur de chaleur a plaques

Typ
Model TL 850 K.IL
Type